

# STRAP SIZING GUIDE

## 1. STRAP SIZE OPTIONS / VELCRO®

**SMALL**  
(PG. 2)

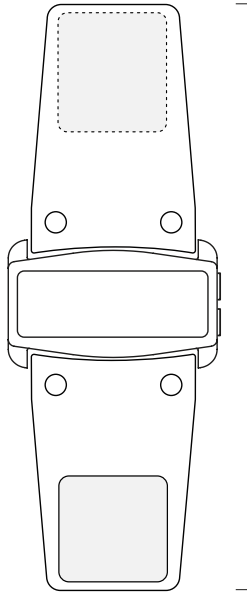

221 mm

**MEDIUM**  
(PG. 3)

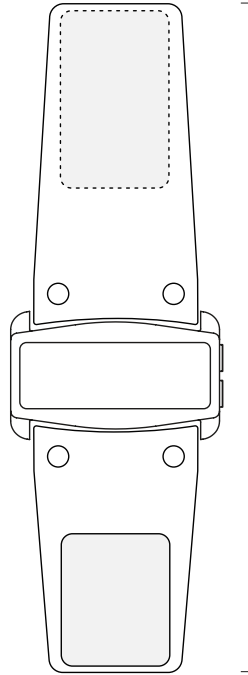

253 mm

**LARGE**  
(PG. 4)

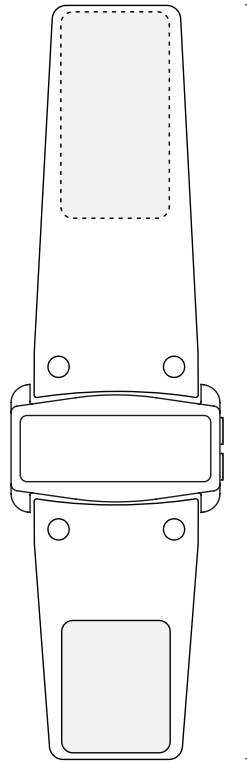

285 mm

## 2. STRAP SIZE OPTION / BUCKLE

**UNIVERSAL**  
(PG. 5)

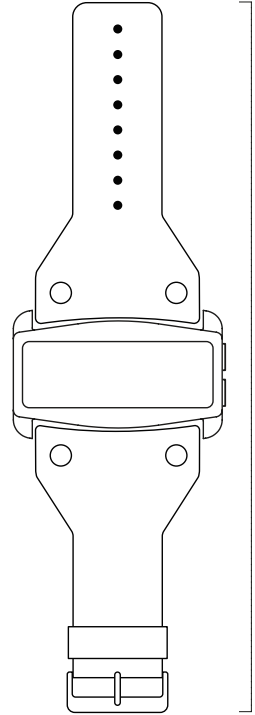

269 mm

## 3. SIZING INSTRUCTIONS

Measure your wrist circumference with a tape measure, or for a more accurate indication of fit, print the watch diagrams from the preceding pages and follow the provided instructions.

Print the appropriate page at 100% in portrait orientation on a sheet of 8.5" x 11" copier paper.

Cut out the watch outline.

Wrap the paper watch outline around your wrist to simulate fit.

A proper fit will have the Velcro areas (grey boxes) matching without too much overlap.

WRAP THE PAPER OUTLINE AROUND WRIST AND ALLOW THE GREY BOXES TO MEET TO INSURE THE VELCRO WILL SECURE PROPERLY.

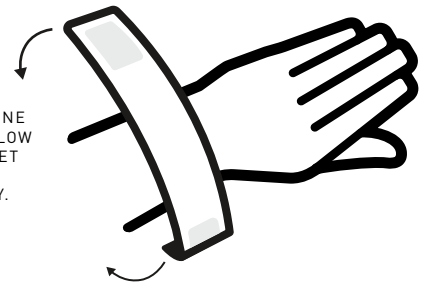

← TOO MUCH OVERLAP. PERHAPS CHOOSE A SMALLER SIZE.

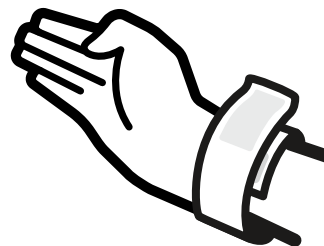

# SMALL

1. STRAP SIZE OPTION SMALL / VELCRO®

**STEP ONE :** Print this page at 100% in portrait orientation on a sheet of 8.5" x 11" copier paper.

**STEP TWO :** Cut out the watch outline by following the dotted guides.

**STEP THREE :** Wrap the paper watch outline around your wrist to simulate fit.

**STEP FOUR :** A proper fit will have the Velcro areas (grey boxes) meeting, but not extending too far.

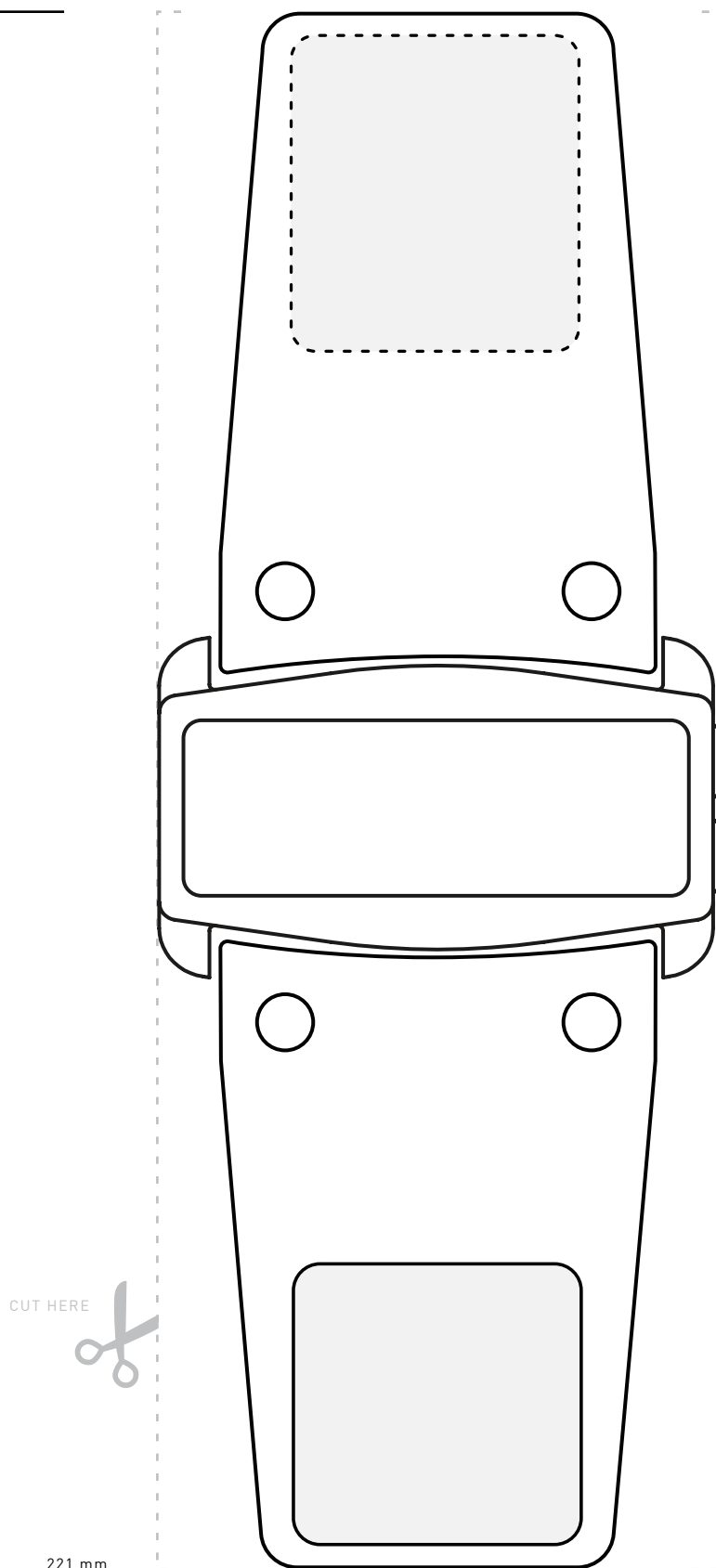

# MEDIUM

1. STRAP SIZE OPTION MEDIUM / VELCRO®

**STEP ONE :** Print this page at 100% in portrait orientation on a sheet of 8.5" x 11" copier paper.

**STEP TWO :** Cut out the watch outline by following the dotted guides.

**STEP THREE :** Wrap the paper watch outline around your wrist to simulate fit.

**STEP FOUR :** A proper fit will have the Velcro areas (grey boxes) meeting, but not extending too far.

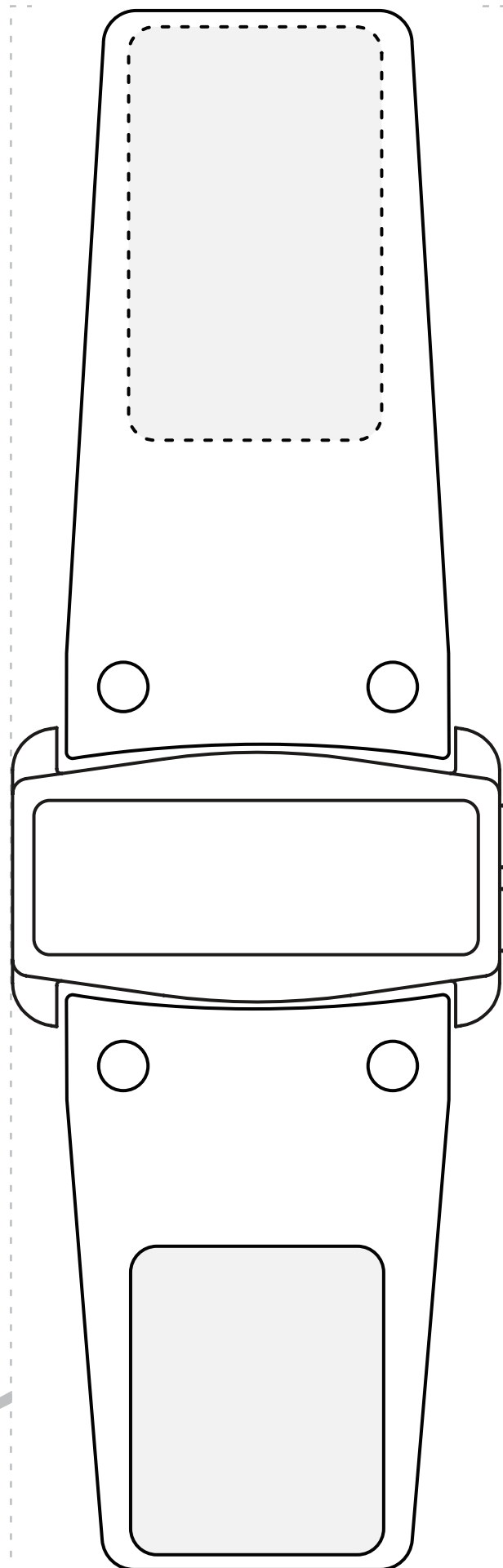

CUT HERE

253 mm

# LARGE

1. STRAP SIZE OPTION LARGE / VELCRO®

**STEP ONE :** Print this page at 100% in portrait orientation on a sheet of 8.5" x 11" copier paper.

**STEP TWO :** Cut out the watch outline by following the dotted guides.

**STEP THREE :** Wrap the paper watch outline around your wrist to simulate fit.

**STEP FOUR :** A proper fit will have the Velcro areas (grey boxes) meeting, but not extending too far.

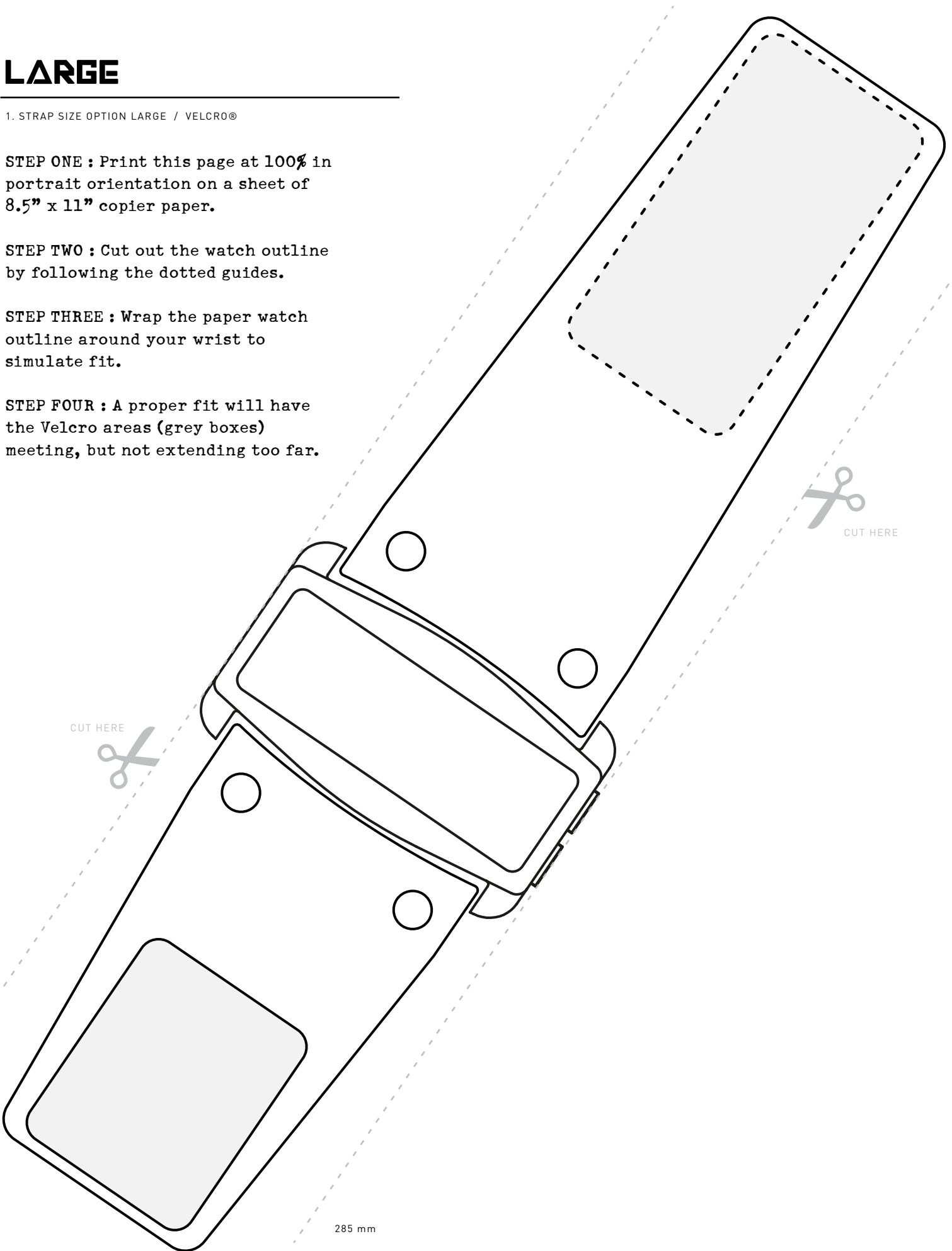

# UNIVERSAL

1. STRAP SIZE OPTION UNIVERSAL / BUCKLE

**STEP ONE :** Print this page at 100% in portrait orientation on a sheet of 8.5" x 11" copier paper.

**STEP TWO :** Cut out the watch outline by following the dotted guides.

**STEP THREE :** Wrap the paper watch outline around your wrist to simulate fit.

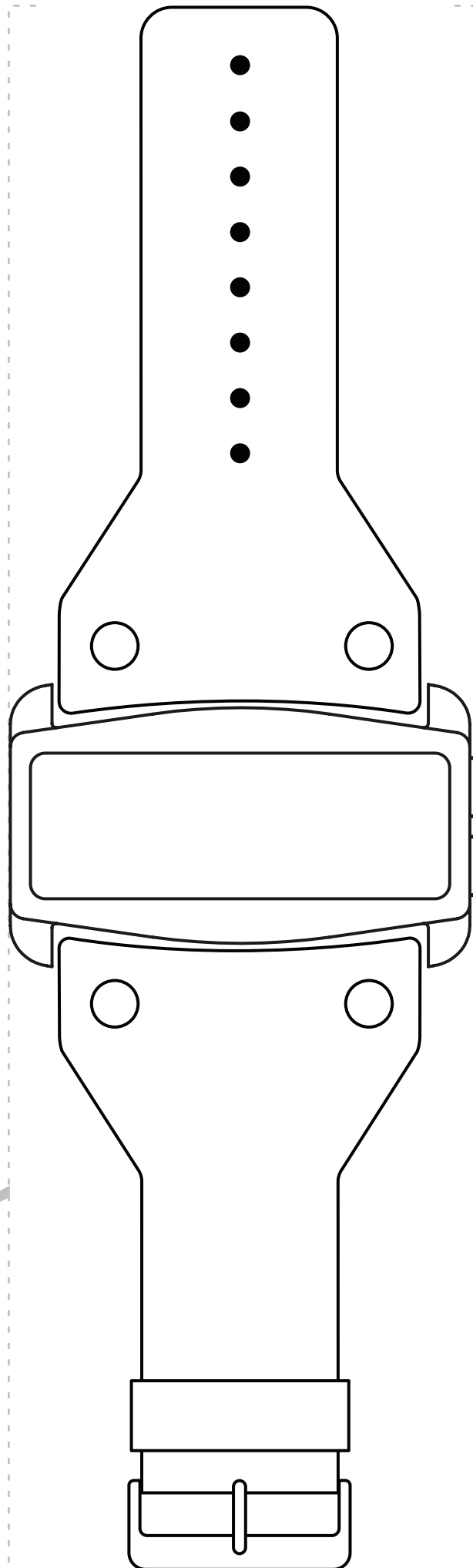

CUT HERE

CUT HERE